

UNIVERSITY OF THE
PACIFIC

Identity Standards Manual

As of 04.14.04

This identity standards manual has been created to preserve the value and unity of University of the Pacific's visual identity. Uniform, high-quality reproduction is critical to ensuring positive impressions. The University of the Pacific Wordmark must always appear crisp, clear and readable. The colors must be consistent regardless of the medium, substrate or process. To ensure uniformity, all reproductions must be taken from approved logo artwork and colors must be carefully matched. The following pages provide a brief set of guidelines to use the Pacific identity correctly.

Table of Contents

Primary Pacific Wordmark

Positive Reproduction	2
Reverse Reproduction	3
Boxed Wordmark	4
Single-Line Wordmark	
Pacific Colors	6-7
Clear Space	8
Minimum Size	9
Typography	10
Incorrect Usage	11
File Naming System	12

Pacific Seal

Usage & Color	13-14
Minimum Size & Clear Space	15
Seal & Pacific Wordmark	16
Incorrect Usage	17

Pacific School Logos

Positive Reproduction	18
Reverse Reproduction	19
Boxed School Logos	20
Single-Line School Logos	21
Minimum Size & Clear Space	22
File Naming System	23

Pacific Letter Formatting

Basic Letterhead	24
Personalized (Dean, Dept., Office)	25
Centered Letterhead	26
#10 Envelope	27
4" x 6" Mailing Labels	28

UNIVERSITY OF THE PACIFIC

Primary Wordmark

The University of the Pacific identity is a customized wordmark.

In its primary form, the wordmark is made up of two typographic components which are stacked to create a visually rectangular shape.

To reproduce the Pacific Wordmark, approved artwork must be used.

Remember: The Pacific Wordmark is a piece of artwork—NOT a font.

It should never be hand-typeset.

The Pacific Wordmark should not be inserted in copy. When the school name appears in copy, it should be spelled out, “University of the Pacific,” or “Pacific.”

Primary Wordmark: 2-Color



Primary Wordmark: 2-Color (Restricted Color Usage)



Primary Wordmark: 1-Color (B/W)



Primary Wordmark: 1-Color Alternate (Orange)



Primary Wordmark: Line Art



Positive Reproduction

For most applications, the primary wordmark should be used in the color variations shown at left.

The two-color primary wordmark is Pacific's predominant mark and should be used for almost all applications. A two-color black and Pacific Orange version has been included for color-restricted usage only.

The one-color, black & white version should be used in one-color situations only (newsprint, etc.), and an alternate one-color version in Pacific Orange has been created for limited situations where black is not an option.

A line art (all black) wordmark should only be used for all black media, such as a fax transmittal cover sheet.

Single-Line Pacific Wordmark

UNIVERSITY OF THE PACIFIC Pacific Orange

UNIVERSITY OF THE PACIFIC Black

Single-Line Wordmark:

Limited Usage Only

A single-line wordmark has been designed for extreme horizontal situations only, such as lower level pages on the Website.

The single-line wordmark should only be used in Pacific Orange or Black.

1-Color (Pacific Orange)



1-Color (B/W)



**Boxed Wordmark:
Limited Usage Only**

The “boxed” wordmark is a variation of the primary wordmark (page 1-3). Its usage is extremely limited and is determined by the complexity of the background onto which it is placed.

The boxed wordmark should only be used on a background—photographic or illustrative—that is too competitive to implement the primary wordmark. A “too competitive” background compromises the legibility of the wordmark, is visually complex, clashes in color, or in some way negatively affects the reproduction and integrity of the wordmark.

The boxed wordmark should never be used on a white background or in any situation that the primary wordmark can be accurately reproduced.

Two versions of this boxed wordmark have been created: One in Pacific Orange when orange is one of the print colors specified; and one in black & white.

Primary Wordmark: 1-Color (B/W)

UNIVERSITY OF THE
PACIFIC White

Reverse Reproduction

When using the primary wordmark on a background that does not have enough contrast in color value to use the positive reproduction versions (see page 2), the one-color (all white) reverse wordmark should be used. This all-white version can be used on any non-competitive background, or can be ghosted out of a 4-color image.

Again, when using the Pacific Wordmark in any of its approved forms, it is critical to ensure that the readability or integrity of the wordmark is never compromised.

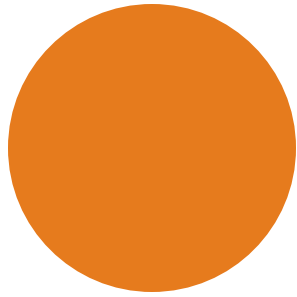

Pacific Orange

Coated Stocks:
PANTONE® 1595 C
(4/C): 65M 100Y
Hex: E1810D
Uncoated Stocks:
PMS or 4/C Process to
Match PANTONE® 1595 C

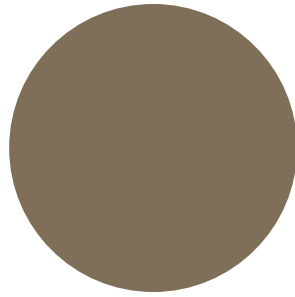

Pacific Gray

Coated Stocks:
PANTONE® Warm Gray 11 C
(4/C): 15M 35Y 60K
(1/C): 65K
Hex: 996C60
Uncoated Stocks:
PMS or 4/C Process to Match
PANTONE® Warm Gray 11 C

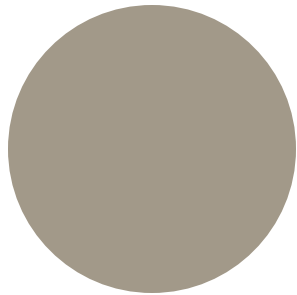

Light Gray

Coated Stocks:
PANTONE® 403 C
(4/C): 10M 20Y 40K
(1/C): 45K
Hex: AA9E8A
Uncoated Stocks:
PMS or 4/C Process to
Match PANTONE® 403 C

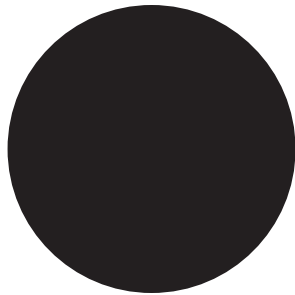

Black

Coated Stocks:
(4/C): 100K or Rich 4/C Black
Hex: 000000
Uncoated Stocks:
100K or Rich 4/C Black

Pacific Colors

The University of the Pacific colors are based on the PANTONE* Color Standard specified below. For matching, refer printers and other suppliers to the current editions of PANTONE Color Publications. Note that the PANTONE Color Standard is specified as C, meaning coated. **All uncoated inks should be mixed to match the coated specifications at left.**

Since differences in substrate and process can affect color, the **CMYK equivalents provided at left are guidelines only and should not be considered to provide an exact match.** To ensure consistent results, always proof carefully against the PANTONE Color Standard.

NOTE: Colors shown throughout this manual are for demonstration purposes only. For accurate color standards refer to the current edition of the PANTONE Color Formula Guide.

*PANTONE is Pantone, Inc.'s check-standard for color reproduction and color-reproduction materials.



Cream

Coated Stocks:
PANTONE® 7527 C
(4/C): 5C 5M 0Y 15Y
Hex: F4EFDD

Uncoated Stocks:
PMS or 4/C Process to
Match PANTONE® 7527 C

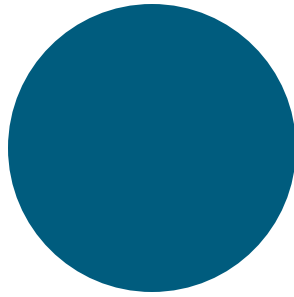

Blue

Coated Stocks:
PANTONE® 5405 C
(4/C): 75C 20M 0Y 45K
Hex: 5F6F7D

Uncoated Stocks:
PMS or 4/C Process to
Match PANTONE® 5405 C

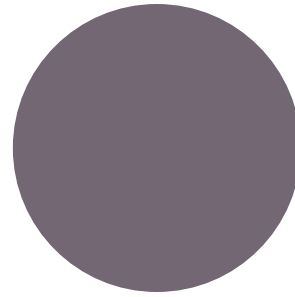

Purple

Coated Stocks:
PANTONE® 5205 C
(4/C): 50C 60M 30Y 0K
Hex: 8B687D

Uncoated Stocks:
PMS or 4/C Process to
Match PANTONE® 5205 C

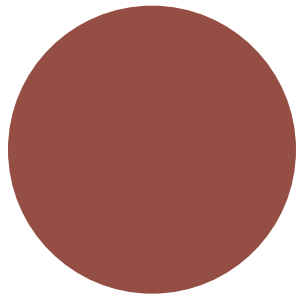

Dusty Red

Coated Stocks:
PANTONE® 4985 C
(4/C): 0C 70M 45Y 40K
Hex: 854A50

Uncoated Stocks:
PMS or 4/C Process to
Match PANTONE® 4985 C

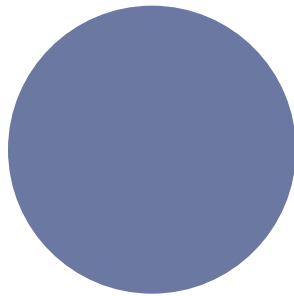

Violet

Coated Stocks:
PANTONE® 5285 C
(4/C): 50C 40M 15Y 0K
Hex: 8581A4

Uncoated Stocks:
PMS or 4/C Process to
Match PANTONE® 5285 C

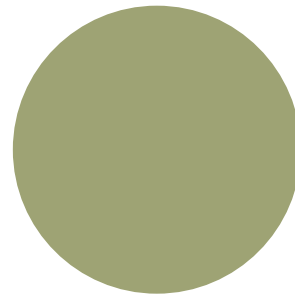

Green

Coated Stocks:
PANTONE® 5773 C
(4/C): 15C 0M 45Y 30K
Hex: A7AB74

Uncoated Stocks:
PMS or 4/C Process to
Match PANTONE® 5773 C

Pacific Accent Palette

Color is essential to the Pacific style, and the accent palette at left has been carefully selected to give users the flexibility needed to meet a large variety of objectives. This extended palette is simply a base of colors that instills a sense of consistency across diverse types of applications and many different layouts. The sophisticated warm and cool color tones all complement the Pacific Identity colors and support the Pacific brand.

The accent palette can be used for typography and solid areas where appropriate. No matter what the usage, the accent palette should always be used sparingly and purposefully.

NOTE: Aside from Pacific Cream, the accent palette should never be used as a background color for the 2-color Pacific Identity or any 3-color School Identity.

Again, since differences in substrate and process can affect color, the **CMYK equivalents provided at left are guidelines only and should not be considered to provide an exact match.** To ensure consistent results, always proof carefully against the PANTONE Color Standard.

*PANTONE is Pantone, Inc.'s check-standard for color reproduction and color-reproduction materials.



Clear Space

The Pacific Wordmark must be surrounded by a clear space at least equal to the cap height of “University of the”—or “x”.

The clear space is measured from the top, right, left, and bottom-most points of the primary or boxed wordmark. As a general rule, more clear space is always preferred.

No other competitive design elements may be positioned within this space, including typography.



.875"
(22.225 mm)



1"
(25.395 mm)

Minimum Size

For Print

The minimum allowable reproduction size for the primary Pacific Wordmark is .875" (22.225 mm) in width, and for the boxed wordmark it is 1" (25.395 mm) in width. Reproduction below these sizes is not recommended since the forms of the wordmark may begin to fill in, thereby compromising readability.

For applications that may require a size smaller than those specified at left, please contact the Marketing Department at for artwork revisions and recommendations.

Primary Typeface

Adobe Garamond Regular

ABCDEFGHIJKLMNOPQRSTUVWXYZ
abcdefghijklmnopqrstuvwxyz
1234567890

Secondary Typefaces

Adobe Garamond Italic

ABCDEFGHIJKLMNOPQRSTUVWXYZ
abcdefghijklmnopqrstuvwxyz
1234567890

Adobe Garamond Bold

ABCDEFGHIJKLMNOPQRSTUVWXYZ
abcdefghijklmnopqrstuvwxyz
1234567890

News Gothic BT Roman

ABCDEFGHIJKLMNOPQRSTUVWXYZ
abcdefghijklmnopqrstuvwxyz
1234567890

News Gothic BT Bold

ABCDEFGHIJKLMNOPQRSTUVWXYZ
abcdefghijklmnopqrstuvwxyz
1234567890

News Gothic BT Italic

ABCDEFGHIJKLMNOPQRSTUVWXYZ
abcdefghijklmnopqrstuvwxyz
1234567890

Franklin Gothic BT Roman

ABCDEFGHIJKLMNOPQRSTUVWXYZ
abcdefghijklmnopqrstuvwxyz
1234567890

Typography

The primary typeface for print is Adobe Garamond Regular. It should be used for main text and for titles that appear separate from text, such as on the cover of a brochure. It should also be used for initial drop caps where appropriate.

The secondary typefaces complement Adobe Garamond Regular and add interest and contrast to layouts.

Adobe Garamond Italic may be used for emphasis within text or as subheads or as large pull quotes.

Adobe Garamond Bold should be used for subhead emphasis within text. (This paragraph is an example.)

News Gothic BT Roman should be reserved for such limited copy elements as pull quotes or photo captions to provide contrast to Adobe Garamond Regular.

News Gothic BT Italic and Bold may be used for emphasis within News Gothic BT Roman text.

The use of **Franklin Gothic BT Roman** should be limited to headlines, titles and initial drop caps when a drop cap in Adobe Garamond Regular is not appropriate.

Do Not
alter the wordmark in any way.



Do Not
reproduce the wordmark in colors other than those specified on pages 2-4.



Do Not
set the wordmark on an angle or reshape it in any way.



Do Not
use any part of the wordmark on its own.



Do Not
reproduce the wordmark at a width smaller than .875", or those indicated on page 8.



Do Not
reproduce the boxed logo in colors other than those specified on page 4.



Do Not
add any modifiers to the wordmark except the approved school lock-ups.



Do Not
alter the wordmark lock-up in any way.



Do Not
set the wordmark on a competitive background that will detract from its readability.



Incorrect Usage

As the key visual expression of our University, we must treat our logo with respect. We must also ensure a singular and unified impression across all the various applications upon which it appears.

The examples at left illustrate unacceptable uses of our wordmark. The Pacific Wordmark must not be compromised or manipulated in any way and should always be reproduced from approved artwork.

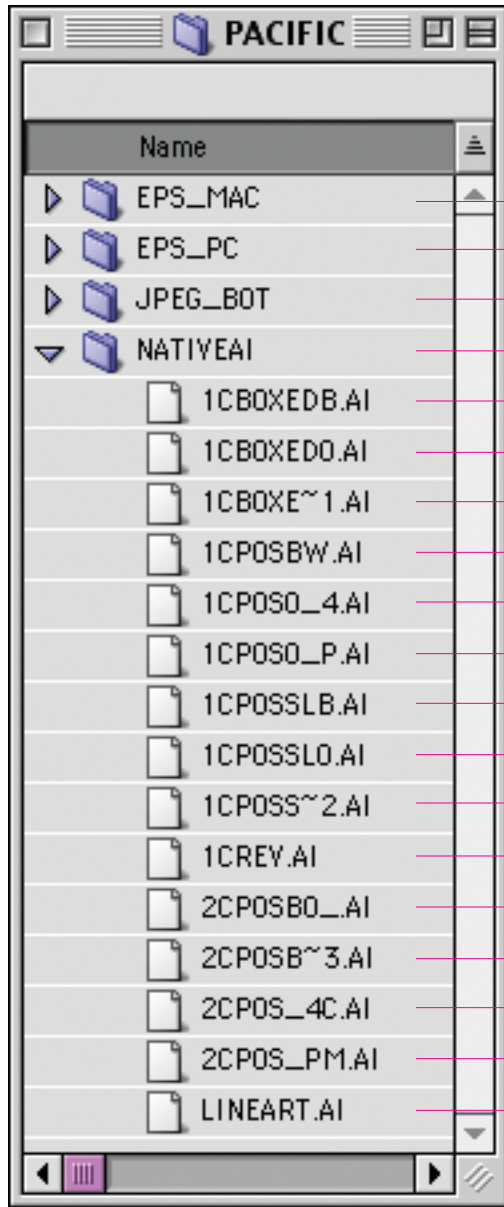

Illustrator EPS files for the Macintosh and PC, same file naming system as below

Jpeg Files for both the Macintosh and PC, same file naming system as below

Native Illustrator 8.0 Files

One-Color Boxed Logo, Black & White

One-Color Boxed Logo, Pacific Orange, 4/C Process

One-Color Boxed Logo, Pacific Orange, PMS

One-Color Positive Logo, Black & White

One-Color Positive Logo, Pacific Orange, 4/C Process

One Color Positive Logo, Pacific Orange, PMS

One-Color Positive Single-Line Logo, Black & White

One-Color Positive Single-Line Logo, Pacific Orange, 4/C Process

One-Color Positive Single-Line Logo, Pacific Orange, PMS

One-Color Reverse Logo, All White

Two-Color Positive Logo, Black & Pacific Orange, 4/C Process

Two-Color Positive Logo, Black & Pacific Orange, PMS

Two-Color Positive Logo, Pacific Gray & Pacific Orange, 4/C Process

Two-Color Positive Logo, Pacific Gray & Pacific Orange, PMS

Line Art Logo, All Black

File Naming System

The file naming system at left has been developed to indicate logo variations for Pacific's final artwork.

Extensions to the file naming system (for School Logos) can be found on page 23.



Pacific Seal

Any collateral, document or piece of merchandise that displays the seal is stating that this material has been officially sanctioned by the University of the Pacific. Because the seal functions as the official signature of the university, it must NOT be altered in any way.

The seal may be used in conjunction with the Pacific Wordmark (see page 14) or on its own. The seal should never be used extraneously to fill space or to create a pattern.

Sample Positive Reproduction (for use on white backgrounds)



Sample Positive Reproduction (for use on backgrounds lighter than the Seal)



Sample Reverse Reproduction (for use on backgrounds darker than the Seal)



Pacific Seal

Color Reproduction

The Pacific Seal can be reproduced in its positive and reverse forms: positive versions for use on lighter backgrounds and reverse versions for use on darker backgrounds.

It is recommended that the seal be reproduced in the approved Pacific palette colors (page 5-6) or as a screen tint of a color to achieve a subtle tone on tone effect. (See sample color combinations at left.) Color usage should never compromise legibility.

The Pacific Seal should only be reproduced in one color. The positive elements of the seal are line art—colors and textures should NEVER be applied into its negative areas.

Clear Space

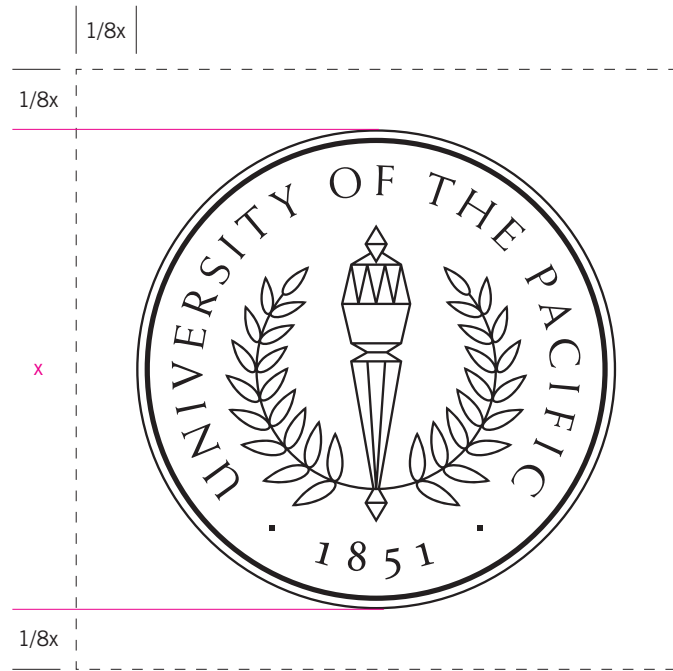

Minimum Size



Pacific Seal

Clear Space

The Pacific Seal must be surrounded by a clear space at least equal to 1/8th the diameter of the seal—or "x".

No other competitive design elements should be positioned within this space, including typography.

Minimum Size for Print

The minimum allowable reproduction size for the Pacific Seal is .875" (22.225 mm) in diameter. Reproduction below this size is not recommended since the forms of the small type and thin rules may begin to fill in, thereby compromising readability.



Pacific Seal

As stated on page 13, the seal may be used in conjunction with the Pacific Wordmark or on its own.

When the seal is used with the Pacific Wordmark, it should function as a secondary element. This can be achieved by using a lighter color for the seal or screening it back behind the wordmark (see examples at left). The Pacific letterhead is also a good example, where the seal is a subtle watermark.

The seal should never be used extraneously to fill space or to create a pattern.

Do Not

alter the proportion of the seal in any way.



Do Not

reproduce the seal with the Pacific wordmark so that it looks like a lock up. (See page 14 for acceptable usage.)



Do Not

crop the seal. (For special needs, please contact the Marketing Department for approval.)



Do Not

delete elements within the seal or extract out parts of the seal.



Do Not

reproduce the wordmark at a width smaller than .875", or those indicated on page 13.



Do Not

create borders or additional art for the seal.



Do Not

reproduce the seal on any complex or patterned background.

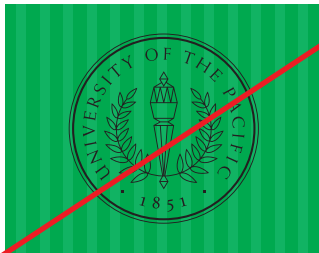

Do Not

print the seal in more than one color or fill in parts of the seal. All transparent areas should show background.



Do Not

print the seal over typography.



Pacific Seal

Incorrect Usage

The Pacific Seal should be considered as one unit—no elements should be altered or manipulated individually. The seal should remain clearly legible at all times and should never be placed on highly textured, complex or patterned backgrounds that would compromise legibility.

The examples at left illustrate unacceptable uses of the Pacific Seal. The seal must not be compromised or manipulated in any way and should always be reproduced from approved artwork.

Eberhardt School of Business

UNIVERSITY OF THE
PACIFIC
Eberhardt School of Business

Gladys L. Benerd School of Education

UNIVERSITY OF THE
PACIFIC
Gladys L. Benerd
School of Education

McGeorge School of Law

UNIVERSITY OF THE
PACIFIC
McGeorge School of Law

College of the Pacific

UNIVERSITY OF THE
PACIFIC
College of the Pacific

**School of Engineering
and Computer Science**

UNIVERSITY OF THE
PACIFIC
School of Engineering
and Computer Science

Conservatory of Music

UNIVERSITY OF THE
PACIFIC
Conservatory of Music

Arthur A. Dugoni School of Dentistry

UNIVERSITY OF THE
PACIFIC
Arthur A. Dugoni
School of Dentistry

School of International Studies

UNIVERSITY OF THE
PACIFIC
School of International Studies

**Thomas J. Long School of
Pharmacy & Health Services**

UNIVERSITY OF THE
PACIFIC
Thomas J. Long School of
Pharmacy & Health Sciences

Pacific School Logos

Like the Pacific Wordmark, the Pacific School Logos are designed to be used as one unit. The type within these wordmarks has been specifically configured and cannot be altered. School Logos must be reproduced from final artwork.

Approved School Logos:

Eberhardt School of Business
College of the Pacific
Arthur A. Dugoni School of Dentistry
Gladys L. Benerd School of Education
School of Engineering and
Computer Science
School of International Studies
McGeorge School of Law
Conservatory of Music
Thomas J. Long School of Pharmacy
& Health Sciences

1-Line School Logo: 3-Color

UNIVERSITY OF THE] Pacific Gray
PACIFIC] Pacific Orange
McGeorge School of Law] Light Gray

1-Line School Logo: 2-Color

UNIVERSITY OF THE] Pacific Gray
PACIFIC] Pacific Orange
McGeorge School of Law] 65% Pacific Gray

1-Line School Logo: 1-Color (B/W)

UNIVERSITY OF THE] 65% Black
PACIFIC] Black
McGeorge School of Law] 45% Black

1-Line School Logo: Line Art

UNIVERSITY OF THE]
PACIFIC] Black
McGeorge School of Law]

2-Line School Logo: 3-Color

UNIVERSITY OF THE] Pacific Gray
PACIFIC] Pacific Orange
Thomas J. Long School of]
Pharmacy & Health Sciences] Light Gray

2-Line School Logo: 2-Color

UNIVERSITY OF THE] Pacific Gray
PACIFIC] Pacific Orange
Thomas J. Long School of]
Pharmacy & Health Sciences] 65% Pacific Gray

2-Line School Logo: 1-Color (B/W)

UNIVERSITY OF THE] 65% Black
PACIFIC] Black
Thomas J. Long School of]
Pharmacy & Health Sciences] 45% Black

2-Line School Logo: Line Art

UNIVERSITY OF THE]
PACIFIC] Black
Thomas J. Long School of]
Pharmacy & Health Sciences]

Pacific School Logos

Positive Reproduction

The schools may either be used in their locked-up, logo version (at left), typeset separately in upper and lower case in Adobe Weiss with an appropriate size relationship to the Pacific Wordmark, or typeset by the specifications on page 3 for a single-line treatment.

The School Logos should never be inserted in copy. When the school name appears in copy, it should be spelled out in the typeface being used.

2-Color Single-Line School Lock-Up

Single-Line Artwork

Approved Colors: Pacific Orange, Black

UNIVERSITY OF THE PACIFIC] x

College of the Pacific x

x = Cap Height of
Non-Curved Letterform
("N" or "T", for example)

Type set in Adobe Weiss

Upper & Lower Case, 40pt Tracking, Kerning as needed, Left Aligned

Approved Colors: Black, Pacific Gray, Light Gray

1-Color Single-Line School Lock-Up

Single-Line Artwork

Approved Colors: Black

UNIVERSITY OF THE PACIFIC] x

Thomas J. Long School of Pharmacy & Health Sciences x

Type set in Adobe Weiss

Upper & Lower Case, 40pt Tracking, Kerning as needed, Left Aligned

Approved Colors: 45% Black

Single-Line School Logos

If a school needs to be defined with the single-line version of the University (see page 3), a lock-up format has been provided. The name of the school should be typeset in Adobe Weiss to the specifications at left. The school name should only be set in upper and lower case—NOT all caps—and should always have the same cap height (height of a non-curved capital letter) as the single-line Pacific artwork.

The space between the “University of the Pacific” and the School equals the cap height, or “x”.

In a two-color lock-up (when the University name is in Pacific Orange), the School name can be typeset in Black, Pacific Gray, or Light Gray. In a one-color lock-up (when the University name is all black), the School name should be typeset in 45% Black.

NOTE: The space between the “University of the Pacific” and the school may need to be altered optically (tightened) when scaled to larger sizes.

1-Line School Logo: 1-Color (B/W)

UNIVERSITY OF THE
PACIFIC
McGeorge School of Law

White

2-Line School Logo: 1-Color (B/W)

UNIVERSITY OF THE
PACIFIC
Thomas J. Long School of
Pharmacy & Health Sciences

White

Pacific School Logos

Reverse Reproduction

When using the School Logos on a background that does not have enough contrast in color value to use the positive reproduction versions (see page 18), the one-color (all white) reverse logo should be used. This all-white version can be used on any non-competitive background, or can be ghosted out of a 4-color image.

Again, when using a School Logo in any of its approved forms, it is critical to ensure that its readability or integrity is never compromised.

1-Line School Logo
1-Color (Pacific Orange)



2-Line School Logo
1-Color (B/W)



2-Line School Logo
1-Color (Pacific Orange)



2-Line School Logo
1-Color (B/W)



**Boxed School Logo:
Limited Usage Only**

The “boxed” wordmark is a variation of the primary wordmark (page 18). Its usage is extremely limited and is determined by the complexity of the background onto which it is placed.

The boxed wordmark should only be used on a background—photographic or illustrative—that is too competitive to implement the primary wordmark. A “too competitive” background compromises the legibility of the wordmark, is visually complex, clashes in color, or in some way negatively affects the reproduction and integrity of the wordmark.

The boxed wordmark should never be used on a white background or in any situation that the primary wordmark can be accurately reproduced.

Two versions of this boxed wordmark have been created: One in Pacific Orange when orange is one of the print colors specified; and one in black & white.



1.125"
(28.574 mm)



1.25"
(31.742 mm)

School Logos Minimum Size

For Print

The minimum allowable reproduction size for Pacific School Logos (either one- or two-line versions) is 1.125" (28.574 mm) in width, and for the boxed wordmark it is 1.25" (31.742 mm) in width. Reproduction below these sizes is not recommended since the forms of the wordmark may begin to fill in, thereby compromising readability.

Clear Space

As specified for the Pacific Wordmark on page 8, a clear space around the equal to the cap height of the letter "U" in "University"—or "x"—should be observed around all School Logos.

No other competitive design elements may be positioned within this space, including typography.

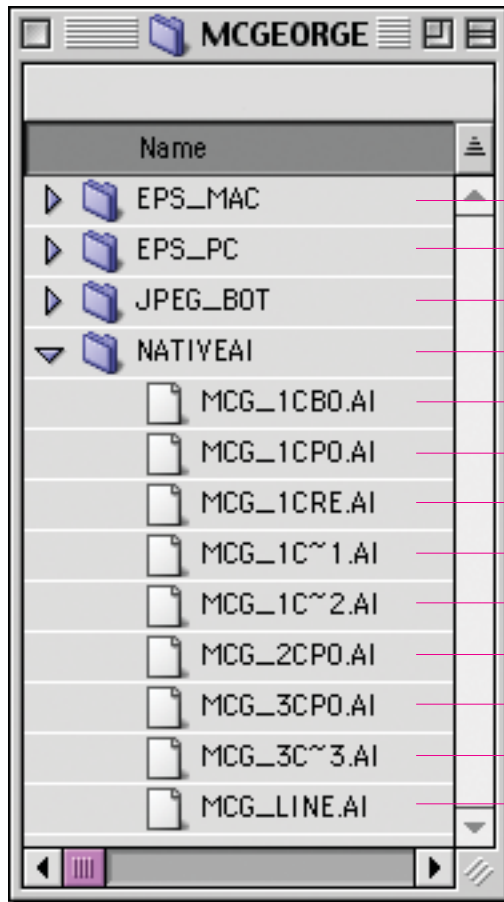

Illustrator EPS files for the Macintosh and PC, same file naming system as below

Jpeg Files for both the Macintosh and PC, same file naming system as below

Native Illustrator 8.0 Files Preceded with a Three Letter School Acronym

One-Color Boxed Logo, Black & White

One-Color Positive Logo, Black & White

One-Color Reverse Logo, All White

One-Color Boxed Logo, Pacific Orange, 4-/C Process

One-Color Boxed Logo, Pacific Orange, PMS

Two-Color Positive Logo, Pacific Gray & Pacific Orange, PMS

Three-Color Positive Logo, 4/C Process

Three-Color Positive Logo, (Pacific Gray, Pacific Orange, PMS 403C) PMS

Line Art Logo, All Black

File Naming System

Three letter acronyms for the School Logos have been added to the Pacific file naming system (page 12) to indicate logo variations. The system for McGeorge School of Law is shown here as an example.

The following three letter acronyms have been used to identify and classify artwork for the nine Pacific schools:

SOB: Eberhardt School of Business

COP: College of the Pacific

SOD: Arthur A. Dugoni School of Dentistry

EDU: Gladys L. Benerd School of Education

ECS: School of Engineering and Computer Science

SIS: School of International Studies

MCG: McGeorge School of Law

MUS: Conservatory of Music

PHS: Thomas J. Long School of Pharmacy & Health Sciences

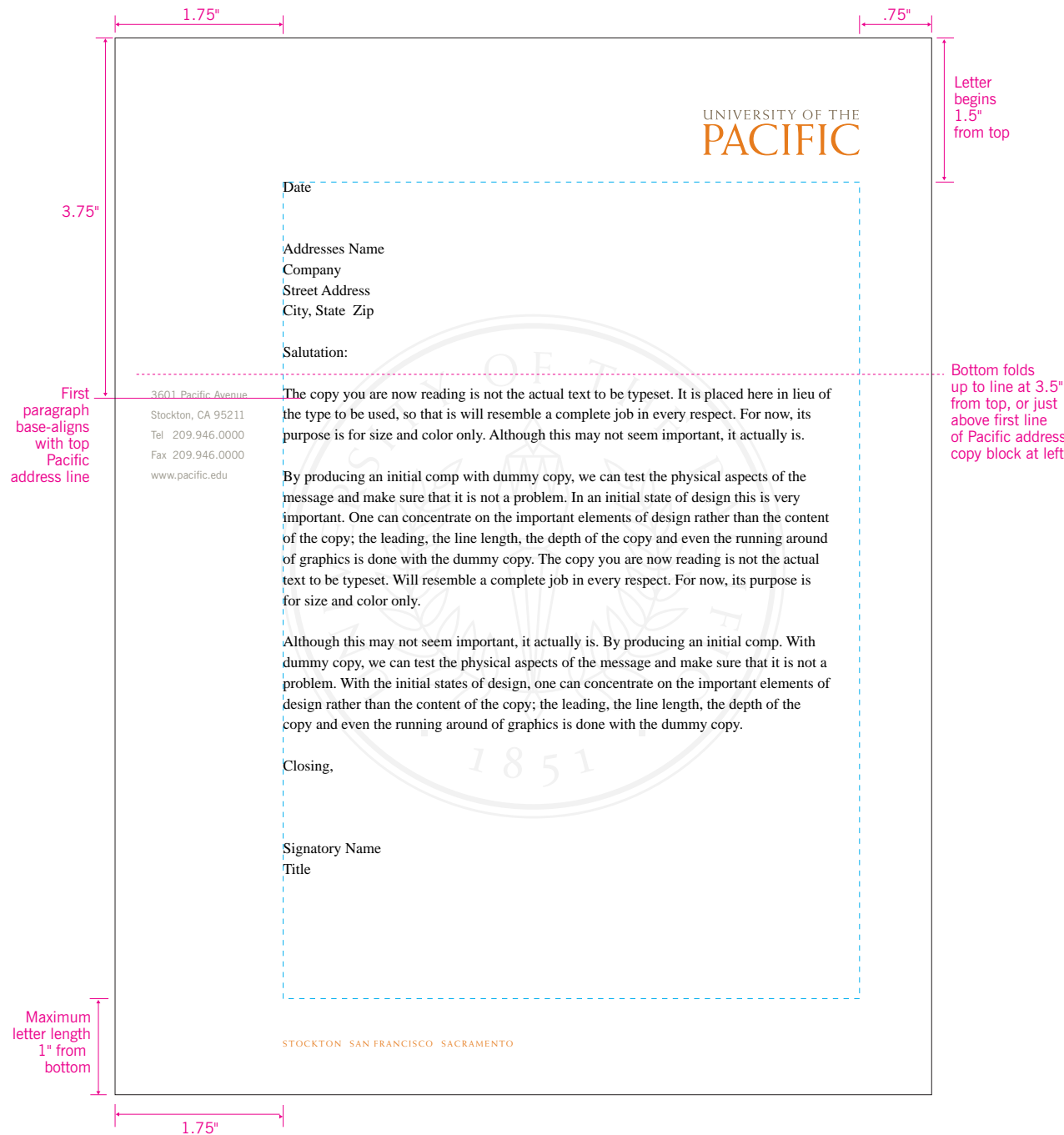

Pacific Basic Letterhead

The Letterhead example at left illustrates the format to be used when typing standard business letters.

The typeface may be either Adobe Garamond or Times Roman (shown). In Microsoft Word, the type size for Times Roman is 11 point with line spacing set at “Exactly” at 15 point (Format > Paragraph > Line Spacing).

Set the top margin at 1.5", the bottom margin at 1", the left margin at 1.75" and the right margin at .75". Begin with the date on the first line. Leave two empty line spaces between the date and address and three line spaces between the closing and signatory name. Leave one empty line space between all other paragraphs.

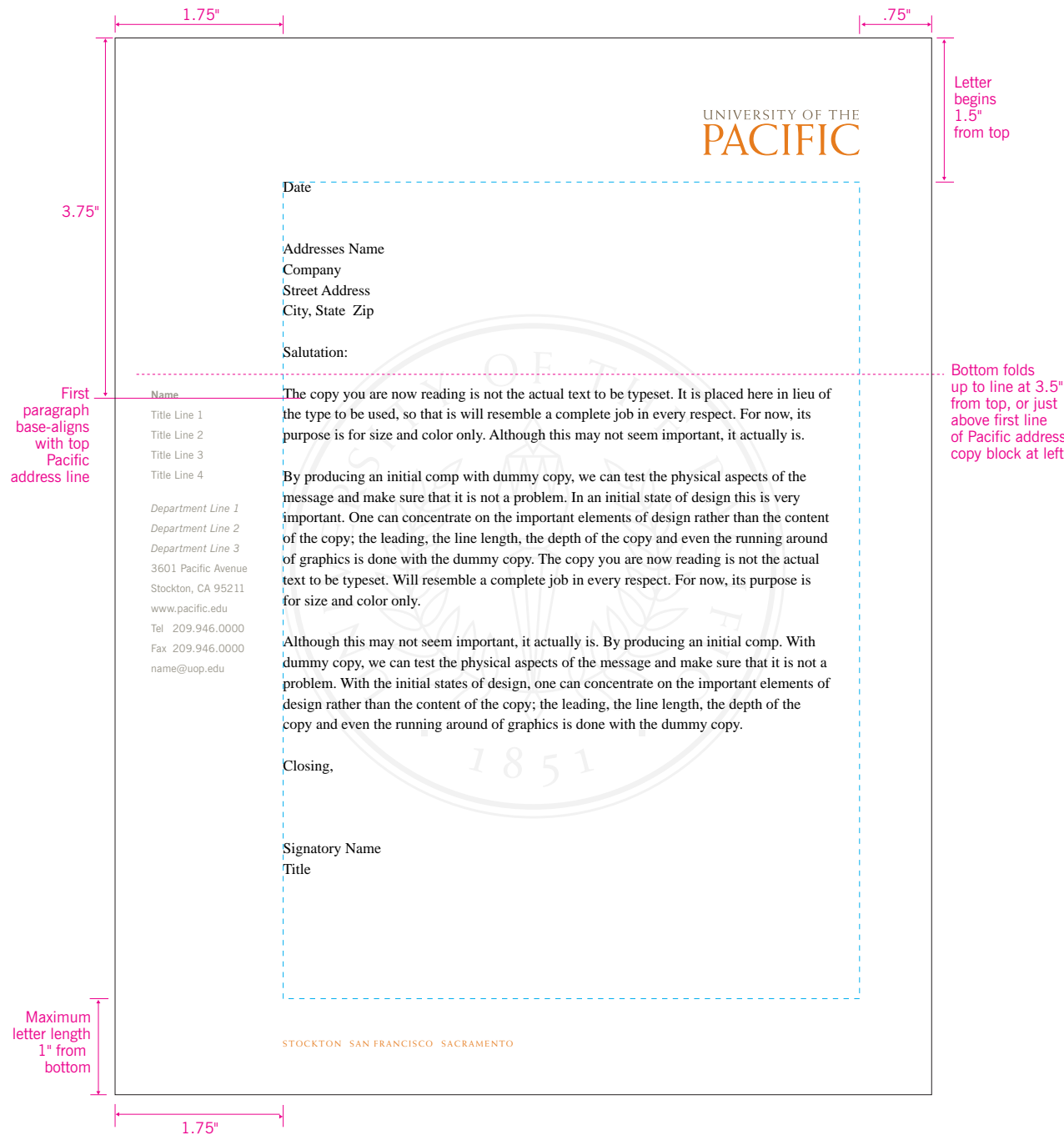

Pacific Personalized (Dean, Department or Office) Letterhead

The Letterhead example at left illustrates the format to be used when typing standard business letters on any personalized, department, or office letterhead.

The typeface may be either Adobe Garamond or Times Roman (shown). In Microsoft Word, the type size for Times Roman is 11 point with line spacing set at “Exactly” at 15 point (Format > Paragraph > Line Spacing).

Set the top margin at 1.5", the bottom margin at 1", the left margin at 1.75" and the right margin at .75". Begin with the date on the first line. Leave two empty line spaces between the date and address and three line spaces between the closing and signatory name. Leave one empty line space between all other paragraphs.

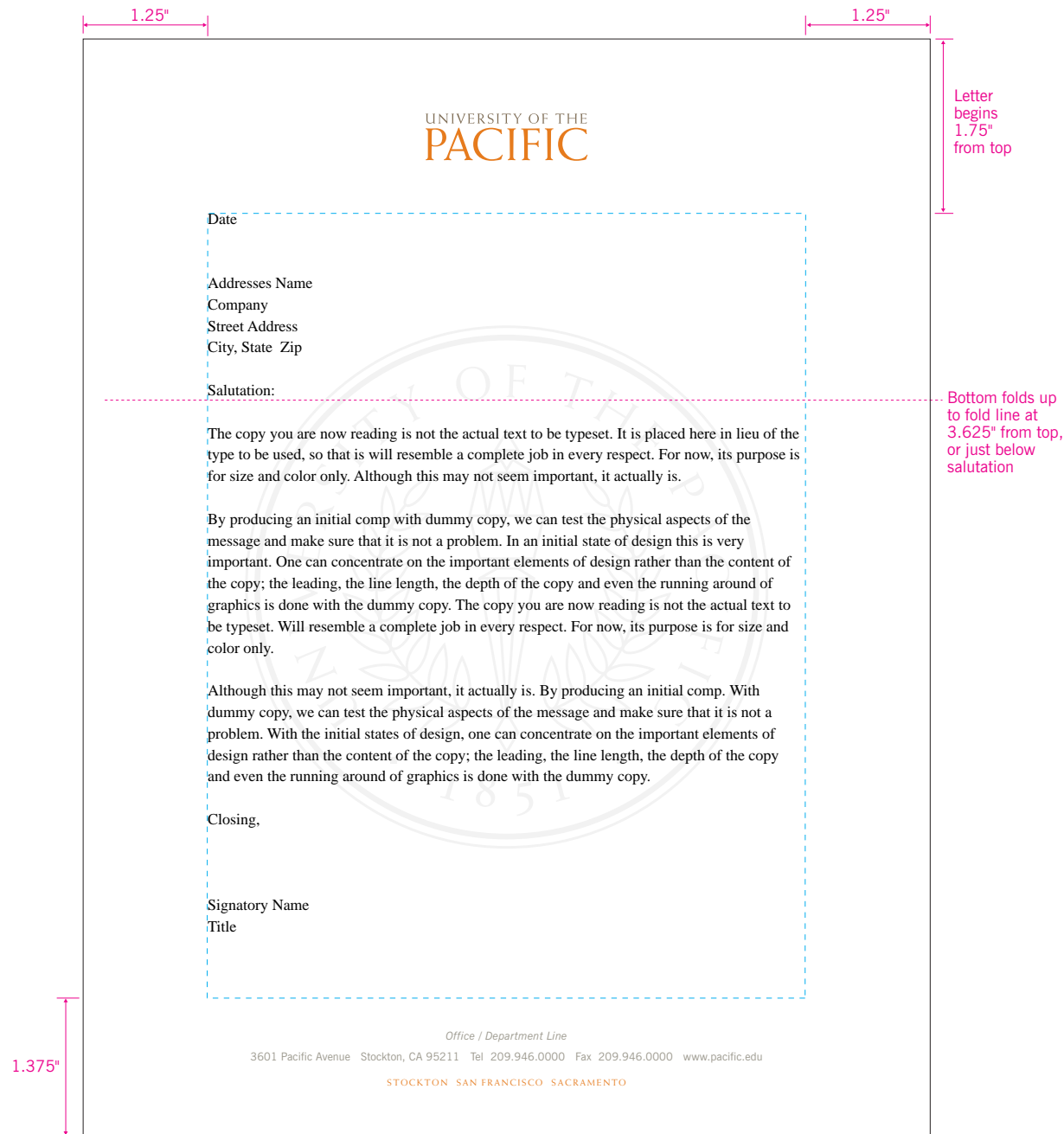

Pacific Centered Letterhead

The Letterhead example at left illustrates the format to be used when typing mass mailings pre-configured for a centered letter format. (Usage for this format is extremely limited.)

The typeface may be either Adobe Garamond or Times Roman (shown). In Microsoft Word, the type size for Times Roman is 11 point with line spacing set at "Exactly" at 15 point (Format > Paragraph > Line Spacing).

Set the top margin at 1.75", the bottom margin at 1.375", the left and right margins at 1.25". Begin with the date on the first line. Leave two empty line spaces between the date and address and three line spaces between the closing and signatory name. Leave one empty line space between all other paragraphs.

Typing Format: Pacific Basic #10 Envelope

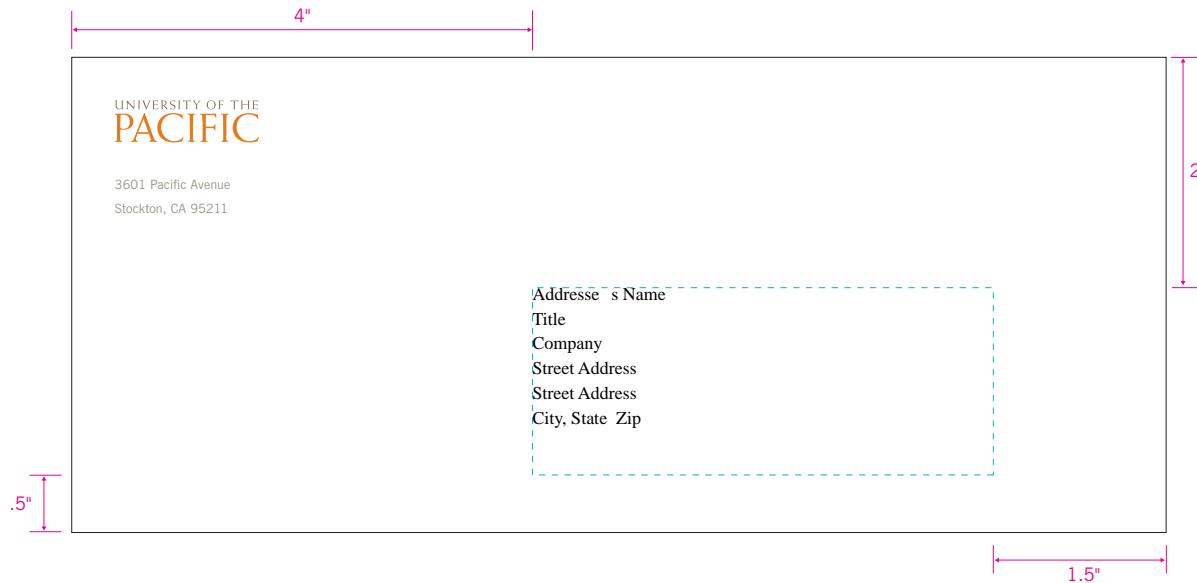

Typing Format: Pacific Personalized #10 Envelope

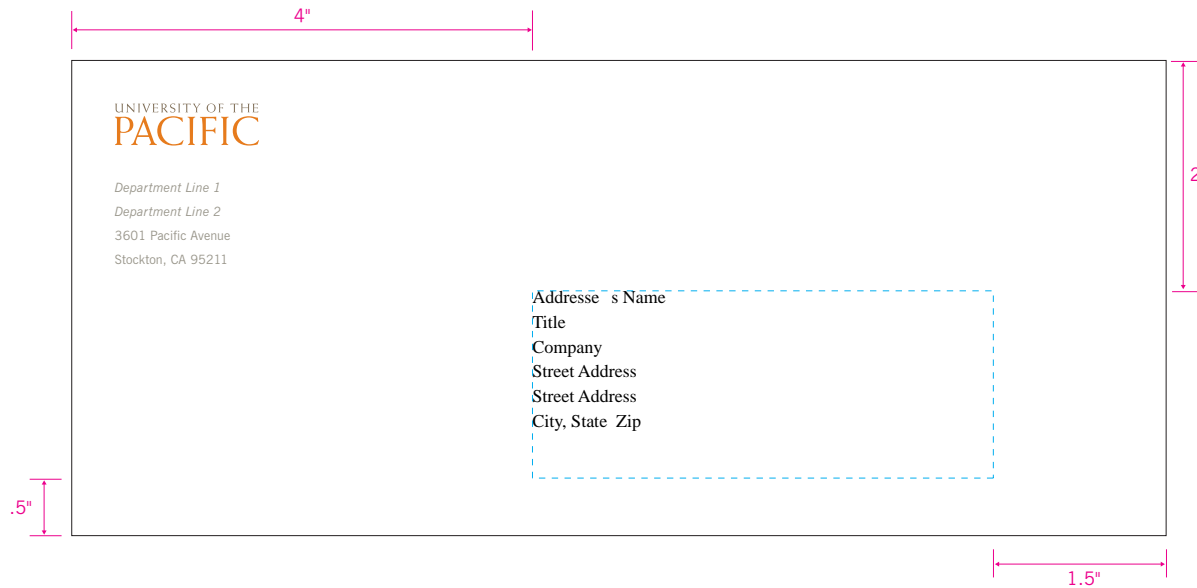

Pacific #10 Envelope

The example below illustrates the typing format to be used on #10 envelopes.

The typeface may be either Adobe Garamond or Times Roman (shown). In Microsoft Word, the type size for Times Roman is 11 point with line spacing set at "Exactly" at 15 point (Format > Paragraph > Line Spacing).

Set the top margin at 2", the bottom margin at .5", the left margin at 4" and the right margin at 1.5". Additional address information (Suite, Floor, Building, Room No., ATTN) would be inserted as separate lines, not to exceed the dotted-lined space specified.

Typing Format: Pacific Basic 4" x 6" Mailing Label

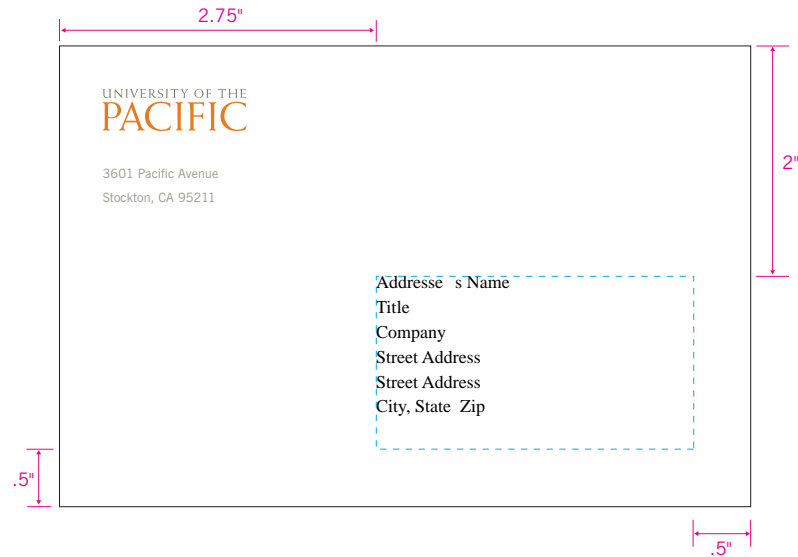

Typing Format: Pacific Personalized 4" x 6" Mailing Label

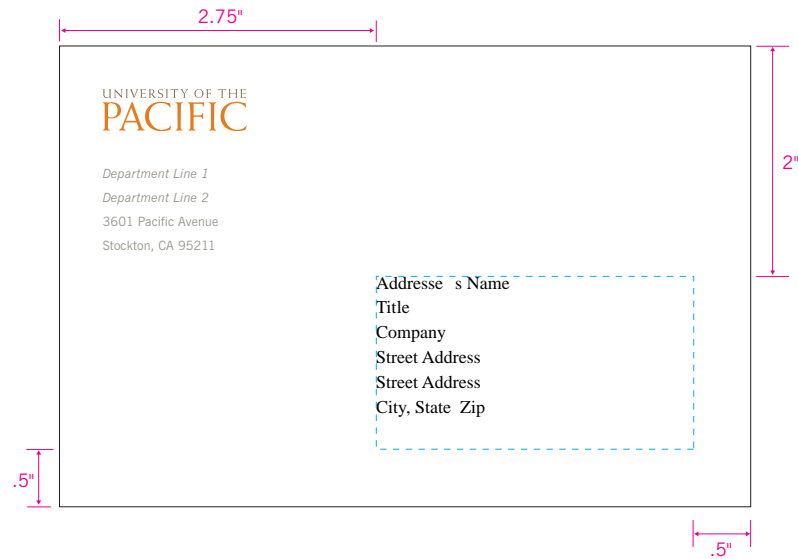

Pacific 4" x 6" Mailing Labels

The example below illustrates the typing format to be used on mailing labels.

The typeface may be either Adobe Garamond or Times Roman (shown). In Microsoft Word, the type size for Times Roman is 11 point with line spacing set at "Exactly" at 15 point (Format > Paragraph > Line Spacing).

Set the top margin at 2", the bottom margin at .5", the left margin at 2.75" and the right margin at .5". Additional address information (Suite, Floor, Building, Room No., ATTN) would be inserted as separate lines, not to exceed the dotted-lined space specified.

Stationery Printing Guide

for the Schools of University of the Pacific

Specifications for Printing & Formatting

As of 04.14.04

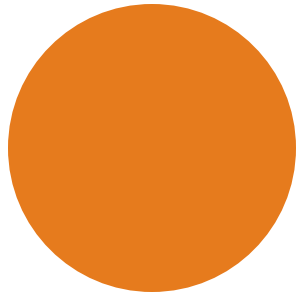

Pacific Orange

Coated Stocks:
PANTONE® 1595 C
(4/C): 65M 100Y
Hex: E1810D
Uncoated Stocks:
PMS or 4/C Process to
Match PANTONE® 1595 C

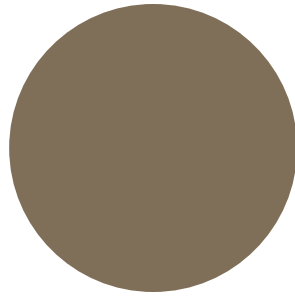

Pacific Gray

Coated Stocks:
PANTONE® Warm Gray 11 C
(4/C): 15M 35Y 60K
(1/C): 65K
Hex: 996C60
Uncoated Stocks:
PMS or 4/C Process to Match
PANTONE® Warm Gray 11 C

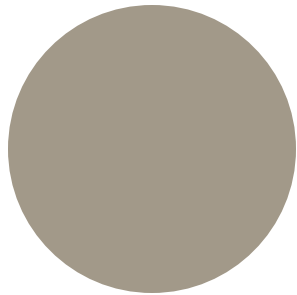

Light Gray

Coated Stocks:
PANTONE® 403 C
(4/C): 10M 20Y 40K
(1/C): 45K
Hex: AA9E8A
Uncoated Stocks:
PMS or 4/C Process to
Match PANTONE® 403 C

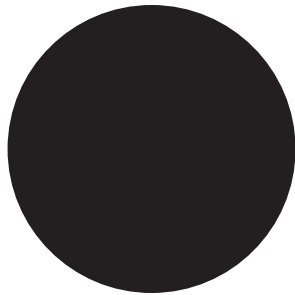

Black

Coated Stocks:
(4/C): 100K or Rich 4/C Black
Hex: 000000
Uncoated Stocks:
100K or Rich 4/C Black

Pacific Colors

The University of the Pacific colors are based on the PANTONE* Color Standard specified below. For matching, refer printers and other suppliers to the current editions of PANTONE Color Publications. Note that the PANTONE Color Standard is specified as C, meaning coated. **All uncoated inks should be mixed to match the coated specifications at left.**

Since differences in substrate and process can affect color, the **CMYK equivalents provided at left are guidelines only and should not be considered to provide an exact match.** To ensure consistent results, always proof carefully against the PANTONE Color Standard.

NOTE: Colors shown throughout this manual are for demonstration purposes only. For accurate color standards refer to the current edition of the PANTONE Color Formula Guide.

*PANTONE is Pantone, Inc.'s check-standard for color reproduction and color-reproduction materials.

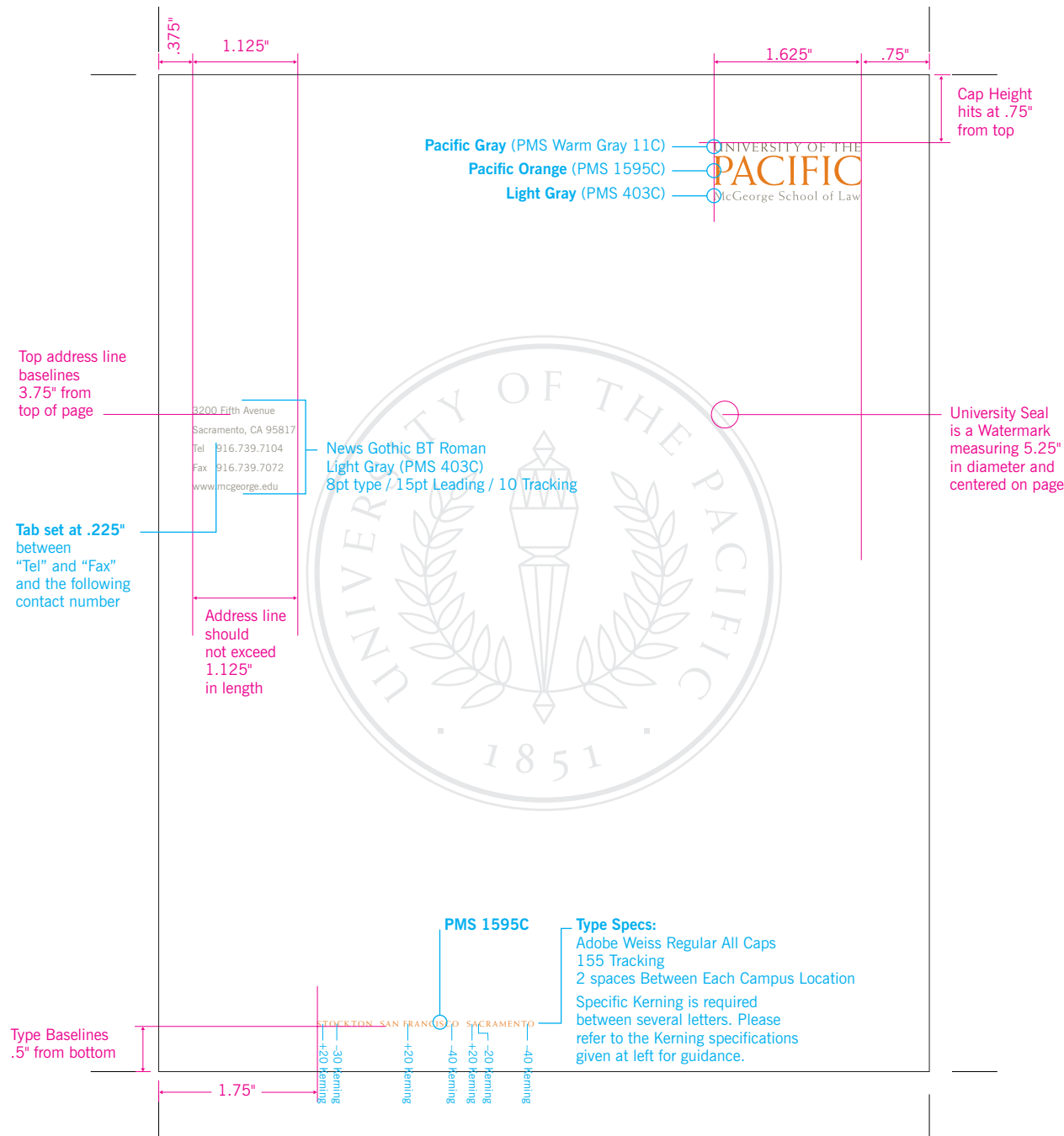

Pacific Schools: Basic Letterhead

Using McGeorge School of Law as an example, the letterhead shown at left contains all the specifications necessary to format Basic Letterhead for your particular School and have it printed.

Whether your School is a two-line or three-line lock-up (see page 18-19 for verification), it will always measure 1.625" in width and align .75" from the top and right of the page.

All PMS colors noted should match the coated PANTONE chip that has been specified.

NOTE: Tracking and kerning can vary from program to program. The specs listed at left are from Adobe Illustrator. If you are creating artwork in any other program, please adjust to achieve the same optical look and feel.

(Example shown at 56% of actual size.)

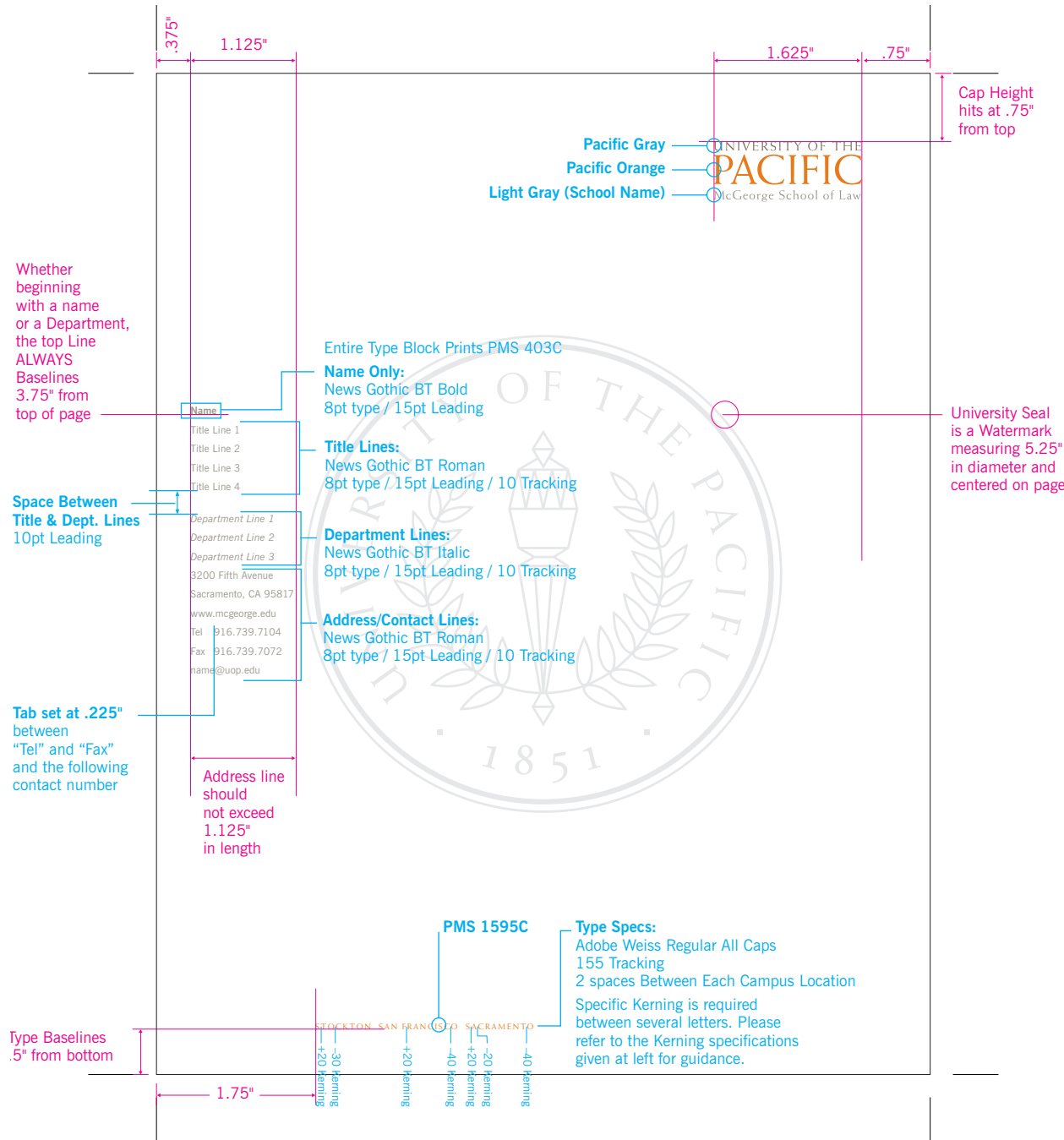

Pacific Schools: Personalized (Dean, Department or Office) Letterhead

Using McGeorge School of Law as an example, the letterhead shown at left contains all the specifications necessary to format Personalized Letterhead for your particular School and have them printed.

Whether your School is a two-line or three-line lock-up (see page 18-19 for verification), it will always measure 1.625" in width and align .75" from the top and right of the page.

All PMS colors noted should match the coated PANTONE chip that has been specified.

When letterhead is personalized and an email address is included, the location of the University's Website moves from below the fax number (see Basic School letterhead on page 30) to below the school address.

NOTE: Tracking and kerning can vary from program to program. The specs listed at left are from Adobe Illustrator. If you are creating artwork in any other program, please adjust to achieve the same optical look and feel.

(Example shown at 56% of actual size.)

Basic #10 Envelope

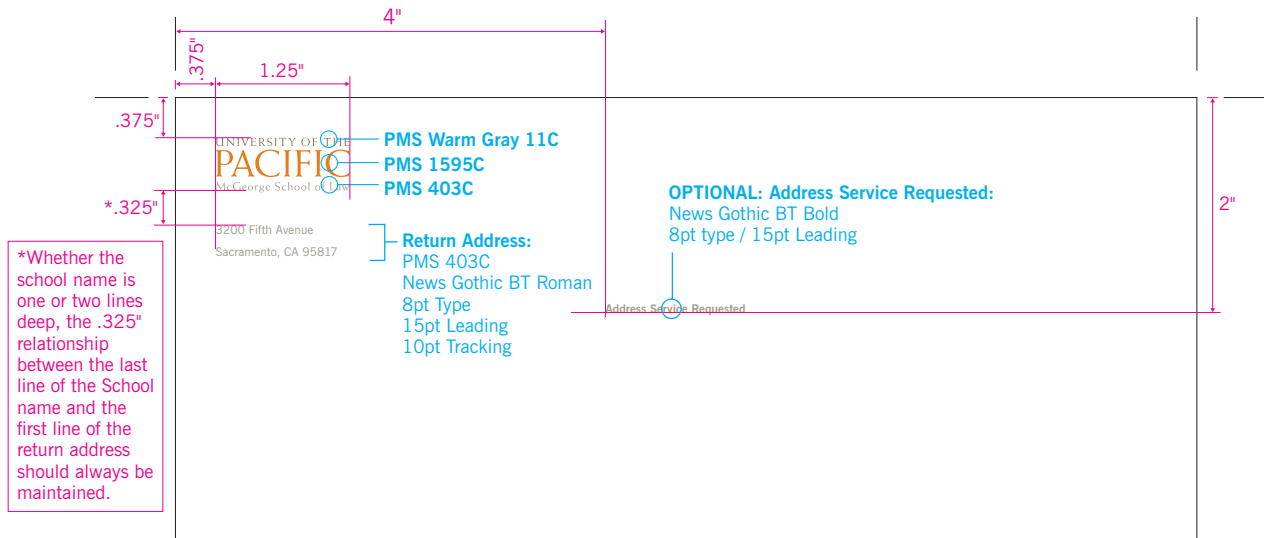

Personalized / Department / Office #10 Envelope

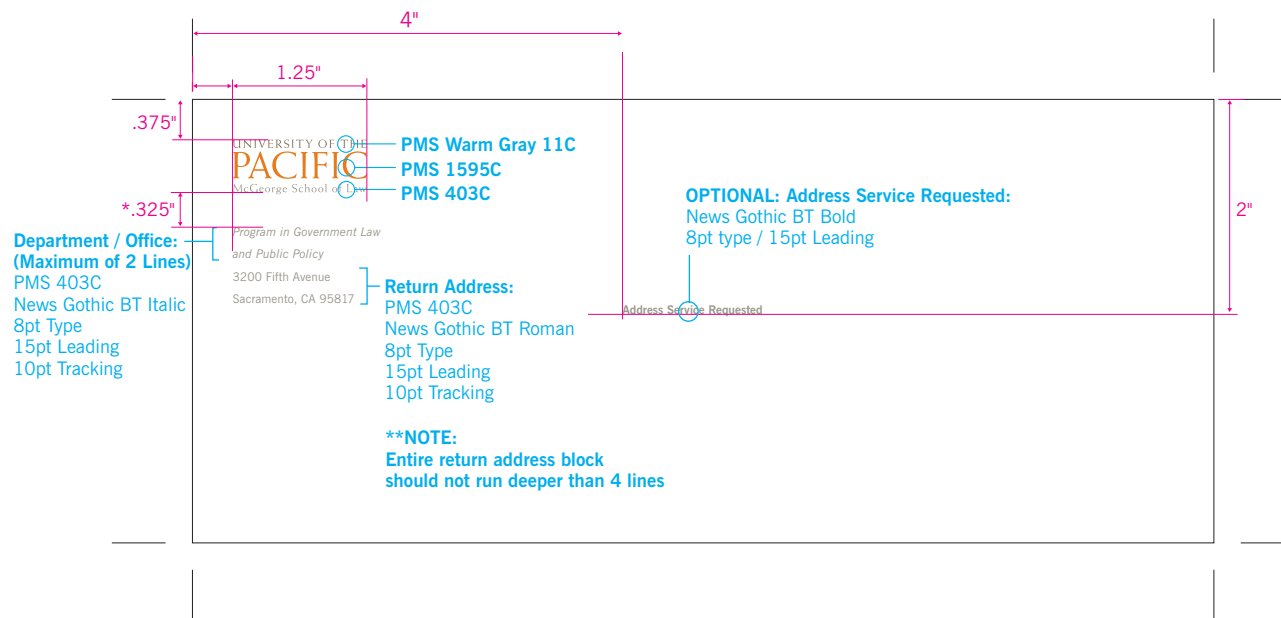

Pacific Schools: #10 Envelopes (Basic & Personalized)

Using McGeorge School of Law as an example, the #10 Envelopes shown at left contains all the specifications necessary to format Basic and Personalized envelopes for your particular School and have it printed.

Whether your School is a two-line or three-line lock-up (see page 18-19 for verification), it will always measure 1.25". The return address will be .325" from the last line of the School name.

All PMS colors noted should match the coated PANTONE chip that has been specified.

NOTE: Tracking and kerning can vary from program to program. The specs listed at left are from Adobe Illustrator. If you are creating artwork in any other program, please adjust to achieve the same optical look and feel.

(Example shown at 56% of actual size.)

Basic 4"x6" Mailing Label

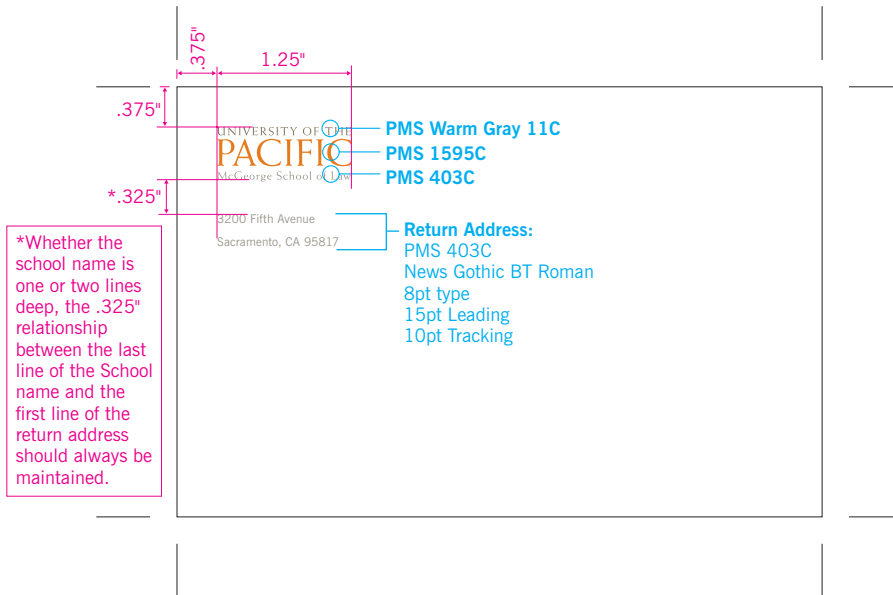

Personalized / Department / Office 4"x6" Mailing Label

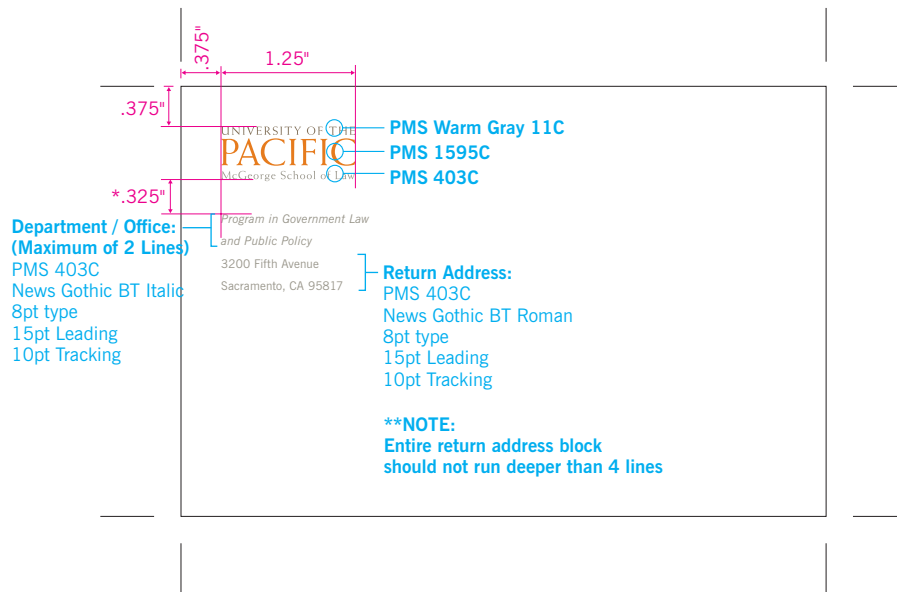

Pacific Schools: 4"x6" Mailing Labels (Basic & Personalized)

Using McGeorge School of Law as an example, the 4"x6" adhesive Mailing labels shown at left contains all the specifications necessary to format Basic and Personalized labels for your particular School and have them printed.

Whether your School is a two-line or three-line lock-up (see page 18-19 for verification), it will always measure 1.25". The return address will be .325" from the last line of the School name.

All PMS colors noted should match the coated PANTONE chip that has been specified.

NOTE: Tracking and kerning can vary from program to program. The specs listed at left are from Adobe Illustrator. If you are creating artwork in any other program, please adjust to achieve the same optical look and feel.

(Example shown at 56% of actual size.)

Business Card Front

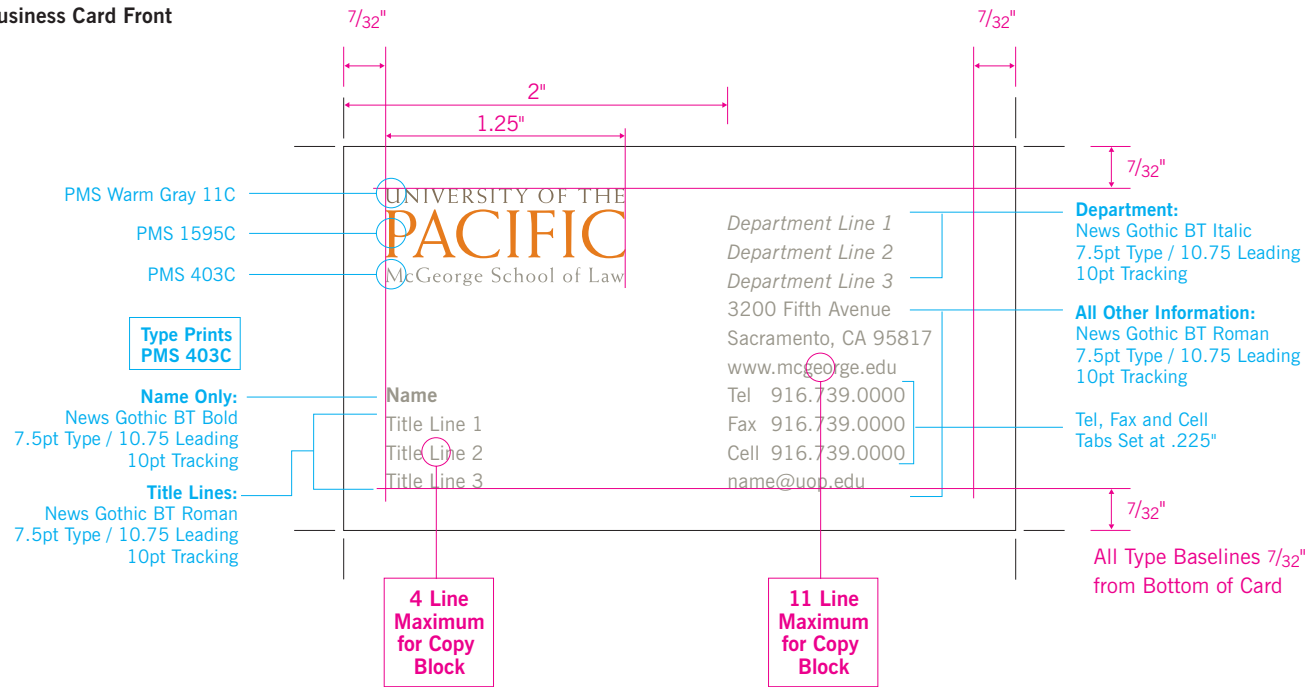

Business Card Back

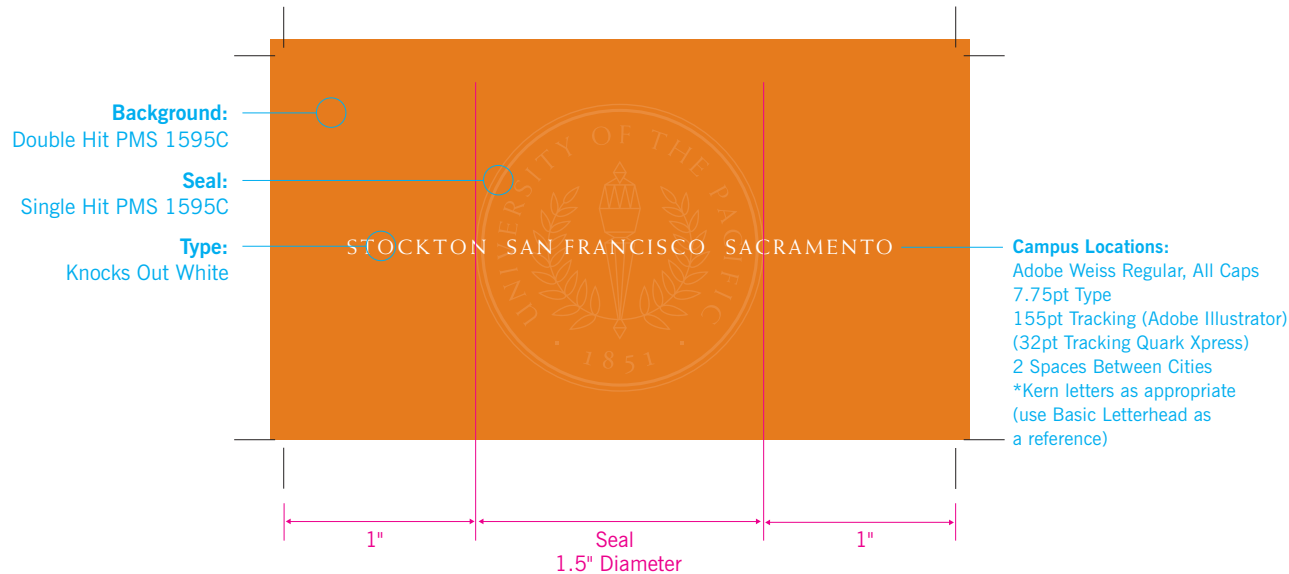

Pacific Schools: Business Cards

Using McGeorge School of Law as an example, the business card front and back shown at left contains all the specifications necessary to format Business Cards for your particular School and have them printed.

Whether your School is a two-line or three-line lock-up (see page 18-19 for verification), it will always measure 1.25" in width and align 7/32" from the top and left of the card trim.

All PMS colors noted should match the coated PANTONE chip that has been specified.

NOTE: Tracking and kerning can vary from program to program. The specs listed at left are from Adobe Illustrator. If you are creating artwork in any other program, please adjust to achieve the same optical look and feel.

(Example shown at 56% of actual size.)